

ABB MEASUREMENT & ANALYTICS | DATA SHEET

AV1 and AV2

Characterizable pneumatic and electro-pneumatic positioners



Measurement made easy

Characterizable analog pneumatic and electro-pneumatic positioners built on proven performance for demanding process conditions

Proven pilot valve

- increased reliability minimizes downtime and maintenance costs

High capacity

- fast response with high air delivery capacity

Performance series

- high flow gain pilot valve body achieves maximum flow capacity at small error signal

Position transmitters

- optional integrated 4 to 20 mA position transmitter

Compact rugged design

- NEMA 4X version available

High vibration and shock environments

- withstands vibration and shock at frequencies to 120 Hz and accelerations to 2 G

Fast, accurate calibration

- independent zero and span adjustments

Single or double-acting without additional hardware

- controls single and double-acting, linear and rotary actuators

AV1 positioner fail-safe with pneumatic input signal

AV2 positioner fail-safe with mA input signal

AV27 positioner fail-safe with mA input signal with explosion-proof I/P converter

Characterizable pneumatic positioners

AV characterizable pneumatic positioners are control devices that satisfy a wide range of applications. They provide fast, sensitive and accurate positioning of pneumatic single- or double-acting, linear or rotary motion actuators. A mechanical connection from the actuator to a position feedback cam in the positioner establishes actual position. Three characterized segments on one cam provide application flexibility by establishing various relationships between input signal and actuator position. The relationships provided by the segments are square root, linear and square.

Using the cam and the zero, span and gain adjustments, the actuator responds with characteristics specific to an application.

An optional manifold assembly provides an integral shutoff and equalizing valve. This isolates the positioner from a double-acting actuator (with manual override) without removing the positioner from the process. The manifold also provides disposable filter cartridges that insure fast servicing and minimum downtime. Manifolds also contain three gage ports for mounting one instrument and two output gages. A supply gage is available and must be piped into the supply line by the user.

AV1 positioners are pneumatic positioners that use a pneumatic input to control the pneumatic output. AV2 positioners are electropneumatic positioners that use an I/P (current-to-pneumatic) converter to accept a 4 to 20 mA input signal and convert it to a pneumatic output.

Some nomenclature options include a high temperature AV1 positioner that can be operated and stored at temperatures up to 127 °C (250 °F). AV2 positioners are available with an explosion-proof I/P converter, external to the housing, that is mounted on an adapter block manifold.

The performance series provides a high flow gain pilot valve body having square ports that provide a maximized air flow for a small motion of the valve stem.

Explosion-proof I/P converter

The AV27 positioner includes an explosion-proof I/P converter mounted to an adapter block manifold. The adapter block manifold is bolted to the outside of the main positioner housing. The unit is an AV12 positioner with the current to pneumatic (4 to 20 mA to 20.7 to 103.4 kPa (3.0 to 15.0 psig)) conversion occurring within the externally mounted I/P converter.

The 4 to 20 mA input signal wires are connected through an explosion-proof conduit entrance on the I/P converter. If no electrical connections are made within the main housing, the entire positioner can be considered suitable for application in the hazardous locations shown on the I/P label. Refer to **Dimensions** on page 10 for the external and mounting dimensions of the positioner.

NEMA 4X

The positioners are available with a NEMA 4X housing. To maintain the NEMA 4X classification, the positioner **must** be installed as described in the NEMA 4X mounting kit. Suitable piping must be attached to the vent opening and vented in a manner to prevent the entrance of water under pressure (for example, from a hose). Additionally, the conduit connections must be suitable for a NEMA 4X rating.

Common specification

Standard stroke range (cam selection)*

AV__1____

12.7 to 50.8 mm (0.5 to 2.0 in) linear, rotary input 45 °

AV__2____

25.4 to 101.6 mm (1.0 to 4.0 in) linear, rotary input 90 °

Gain

Two adjustment levels via gain hinge spring change for standard and performance series (high gain) units are available.

Supply pressure**

172 to 1,034 kPa (25 to 150 psig)

Supply pressure effect

0.05 % per 6.9 kPa for ±69 kPa change
(0.05 % per 1.0 psig for ±10 psig change)

Air consumption

See Figure 1 on page 5

Capacity

Maximum capacity exhausted to atmosphere –
see Figure 2 on page 5

Vibration effect***

<2,0 % error for:

- 5 to 115 Hz at peak-to-peak constant displacement to 4 mm (0.16 in)
- 15 to 120 Hz at acceleration to 2 G.

Pneumatic connections

¼ NPT on supply, signal and output connections

⅜ NPT on pressure gages

Materials of construction

Enclosure

Aluminum and <0.5 % magnesium

Pilot valve

303 stainless steel

Enclosure classification

Standard

- NEMA 3R classification when vent hole is protected from rain using rain elbow (½ NPT street elbow, see Figure 10 on page 11)
- NEMA 4X classification with option AV_____N.

* Use 90° cam whenever possible

** Minimum supply pressure must be 34.4 kPa (5.0 psig) above the required operating pressure

*** Tested according ISA-S75, 13 – 1989

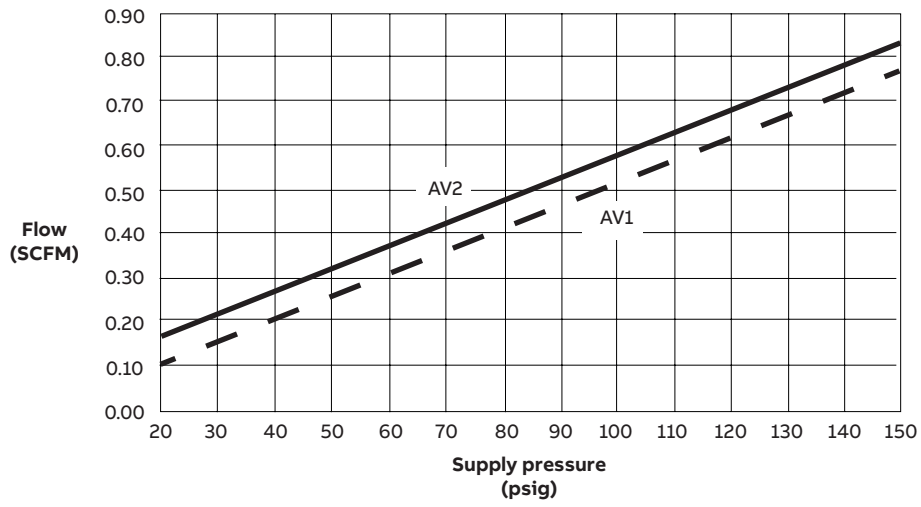

Figure 1 Air consumption (at null)

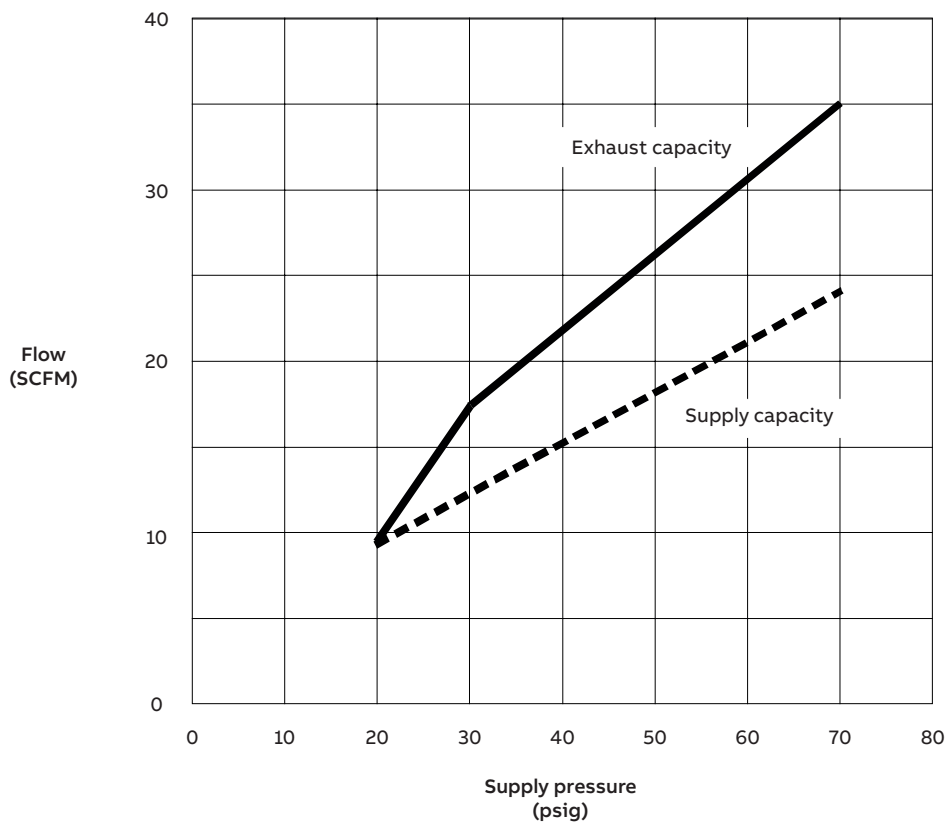

Figure 2 Capacity (exhaust to atmosphere)

AV1 positioner specification

Operation

Input range*

- AV11 and AV15
 - 20.7 to 103.4 kPa (3.0 to 15.0 psig)
- AV12 and AV16
 - 20.7 to 186.2 kPa (3.0 to 27.0 psig)

Accuracy**

0.80 % of span maximum

Resolution

0.09 % of span maximum

Hysteresis**

0.45 % of span maximum

Repeatability**

0.12 % of span maximum

Deadband**

0.12 % of span maximum

Linearity**

0.70 % of span maximum

Weight

1.84 kg (4.06 lb)

Temperature limits

Operating***

AV11/2 –40 to 82 °C (–40 to 180 °F)

AV15/6 –20 to 121 °C (–4 to 250 °F)

Storage

AV11/2 –40 to 93 °C (–40 to 200 °F)

AV15/6 –20 to 121 °C (–4 to 250 °F)

Humidity limits – operating and storage

0 to 95 % non condensing

AV2 positioner specification

Operation

Input range*

4 to 20mA

Input impedance

250 Ω at 20 mA

Accuracy**

0.90 % of span maximum

Resolution

0.30 % of span maximum

Hysteresis**

0.70 % of span maximum

Repeatability**

0.50 % of span maximum

Deadband**

0.30 % of span maximum

Linearity**

0.70% of span maximum

Weight

Standard model

2.32 kg (5.11 lb)

Explosion-proof model

2.95 kg (6.51 lb)

Temperature limits

Operating***

–20 to 82 °C (–4 to 180 °F)

Storage

–20 to 80 °C (–4 to 176 °F)

Humidity limits

Operating and storage

0 to 95% non condensing

* Units have 50 % range suppression and / or zero elevation capability.

** Tested according ISA-S75, 13 – 1989

*** For operation below 4.4 °C (40 °F), dew point of supply air must be 10 °C (18 °F) lower than lowest expected operating temperature

AV1/2_ _ _1 position transmitter specification

Total resistance

2000 Ω , $\pm 20\%$ potentiometer

Power rating

- 1 W up to 70 °C (158 °F),
- 0 W at or above 125 °C (257 °F)

Wiper rate of change

9.9 Ω nominal per degree of cam rotation

Temperature effect

0.05 % (500 ppm) per °C (0.03 % [278 ppm] per °F)
maximum

Maximum voltage

35 V DC or 30 V AC across the potentiometer ends

Temperature limits

Operating

–40 to 82 °C (–40 to 180 °F)

Storage

–40 to 93 °C (–40 to 200 °F)

Operation

AV positioners operate by balancing opposing forces. Figure 3 is an operational diagram of the positioner. A balance beam, hinged at one end and connected to the pilot valve at the other, is acted upon by two forces:

- upward force of the signal diaphragm assembly
- downward force from the range spring

A change in input signal changes the force exerted by the signal diaphragm, moving the balance beam, in turn moving the pilot valve. The pilot valve supplies and / or exhausts air to the actuator that ultimately changes its position. The change in actuator position is fed back to the positioning cam. The positioning cam moves, changing the tension of the range spring until a balanced condition once again exists.

The input signal pressure determines the diaphragm force. The AV1 positioner uses an external input pressure (either 20.7 to 103.4 kPa (3.0 to 15.0 psig) or 20.7 to 186.2 kPa (3.0 to 27.0 psig)). AV2 positioners internally generate the input signal pressure using an I/P converter.

The range spring force is a function of the shape and position of the cam. The cam is coupled to the cam shaft that is connected through linkage (or coupling) to the actuator. Therefore, range spring tension is a function of the actuator position.

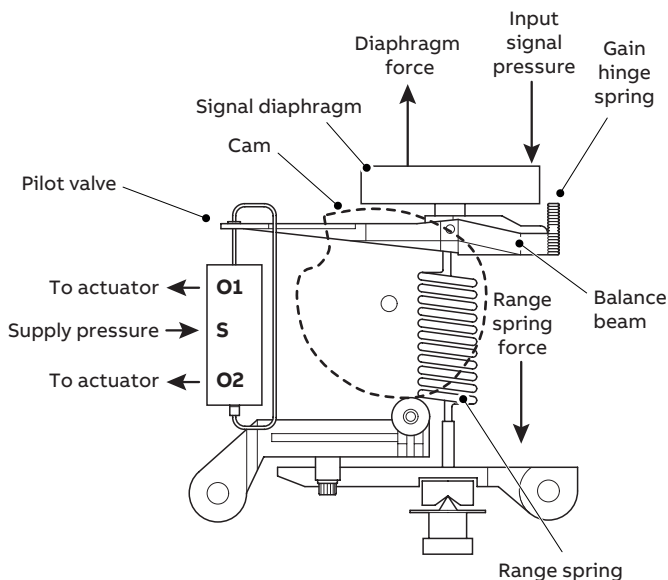

Figure 3 Operation diagram

AV1 pneumatic positioner

AV1 positioners receive an external pneumatic signal and converts it to a pneumatic output. This output produces the motive force that positions the power actuator. The AV1 fails safe open / closed on loss of current input signal.

AV2 4 to 20 mA I/P positioners

AV2 positioners receive a current input (4 to 20 mA) from the control device and convert the signal to a pneumatic signal. This pneumatic signal is converted to a pneumatic output that produces the motive force that positions the actuator. The AV2 fails safe open / closed on loss of current input signal.

Position transmitters

Two types of position transmitters are available on AV1 and AV2 positioners.

The potentiometric position transmitter uses a high durability plastic film potentiometer to indicate the position of the cam shaft. The resulting resistive value is a function of the shaft position. The resistive output can be used for additional control purposes.

The 4 to 20 mA position transmitter uses a high durability plastic film potentiometer to indicate the cam shaft position. The resulting resistive value is sent to an electronics assembly that produces a proportional 4 to 20 mA signal. This signal can be used for additional control purposes.

Performance series

The performance series provides a high flow gain pilot valve body with square ports that provide maximized air flow for a small motion of the pilot valve stem. A relatively small error signal can therefore cause a relatively large change in output air flow to the actuator. This feature is useful when driving larger actuators that might otherwise be insensitive or slow to respond to small signal changes.

Compared to other positioners on the market, the standard AV positioners have a high delivery capacity. The flow gain curves shown in Figure 4 and Figure 5 show output air flow versus input error signal for the standard and high-gain performance series positioners.

Figure 4 and Figure 5 show that the large signal maximum air flow for both the standard and performance series positioners is about the same. The performance series positioners achieve maximum flow capacity at a much smaller error signal. Avoid using a performance series positioner on a small actuator as it could cause instability.

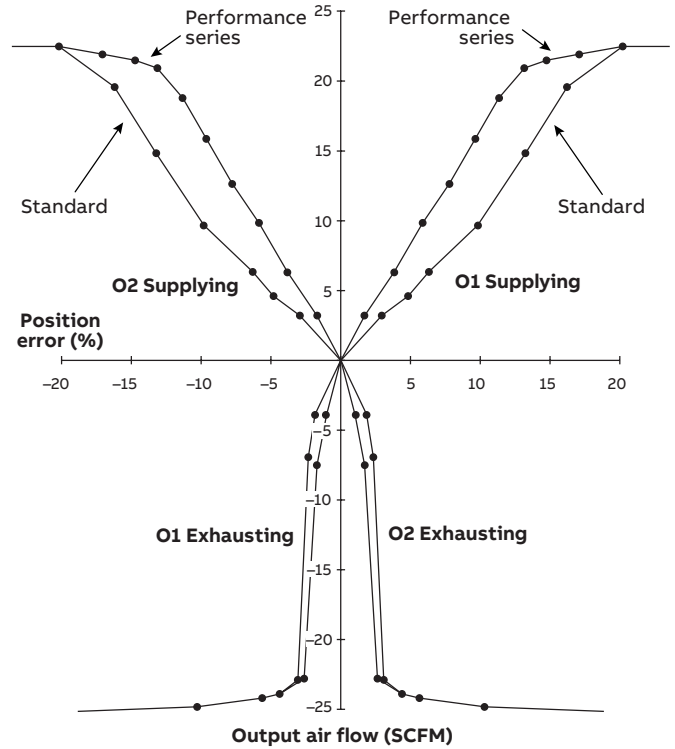

Figure 4 Output air flow versus error signal - standard and performance series

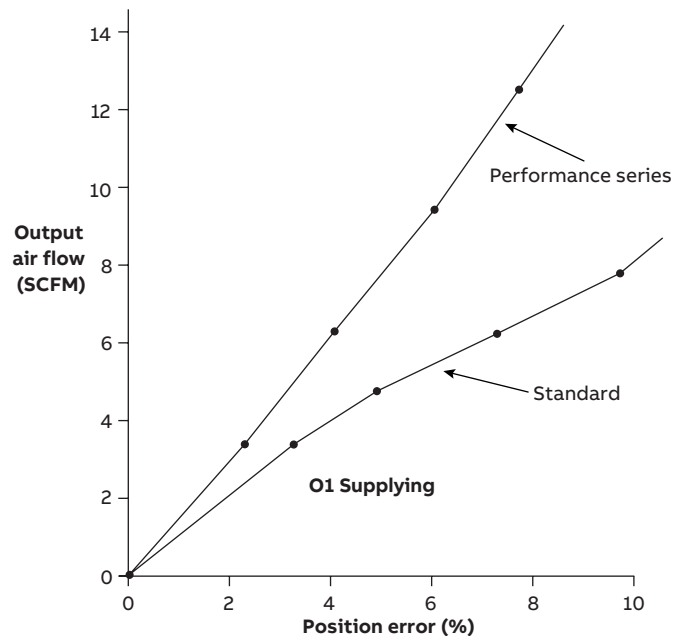

Figure 5 Expanded first quadrant view of Figure 4

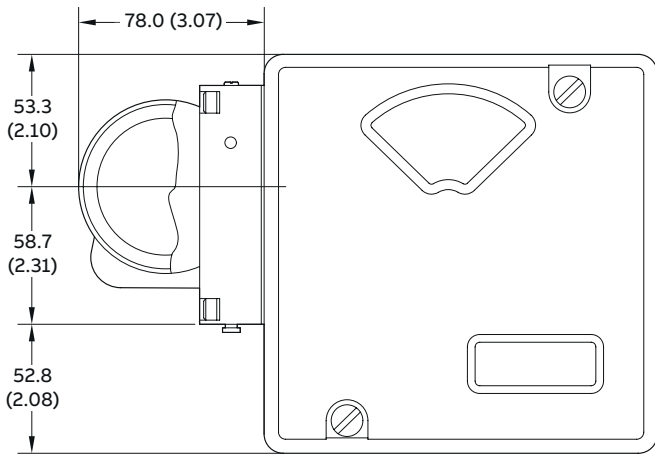

Figure 7 View with explosion proof I/P converter

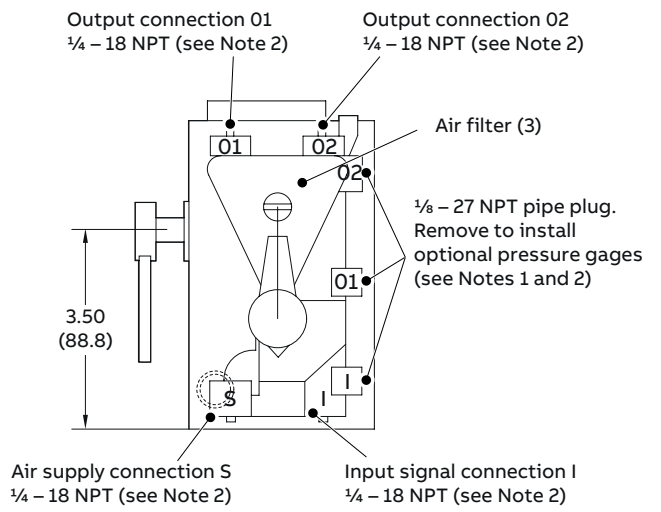

Figure 9 View with optional manifold

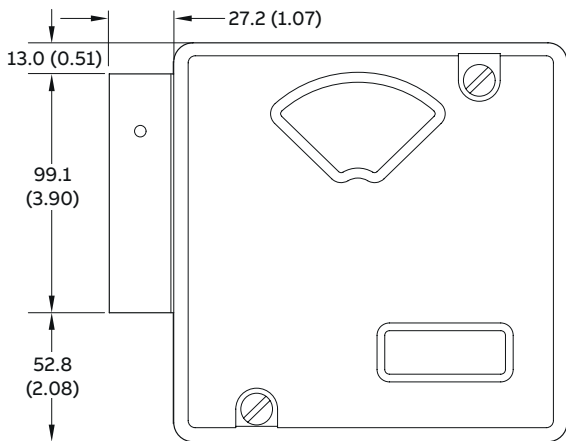

Figure 8 View with gage block

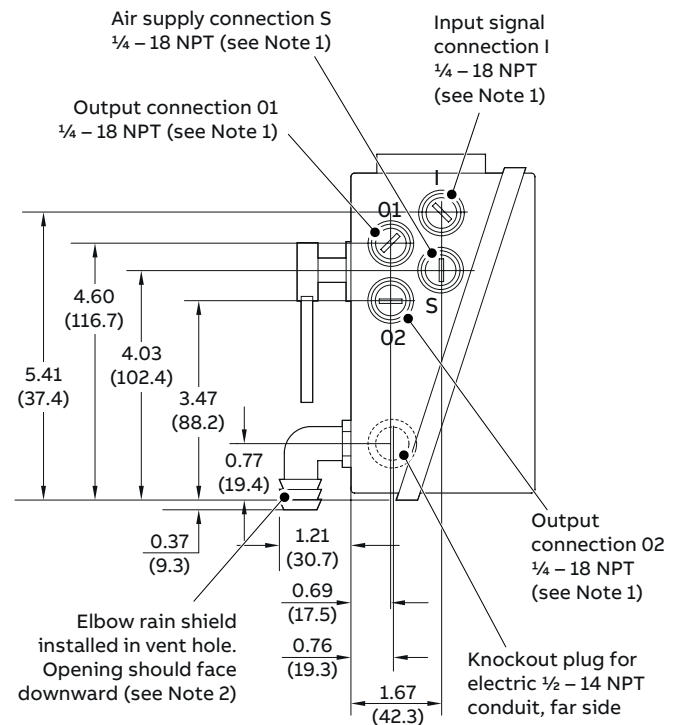

Figure 10 View without optional manifold

Notes.

- 1 Pressure gages are available as an accessory only and must be installed by the customer.
- 2 Use liquid or paste pipe sealant on fittings. Do not use Teflon tape.

Notes.

- 1 Use liquid or paste pipe sealant on fittings. Do not use Teflon tape.
- 2 Street elbow can be obtained from ABB.

...Dimensions

Dimensions in mm (in)

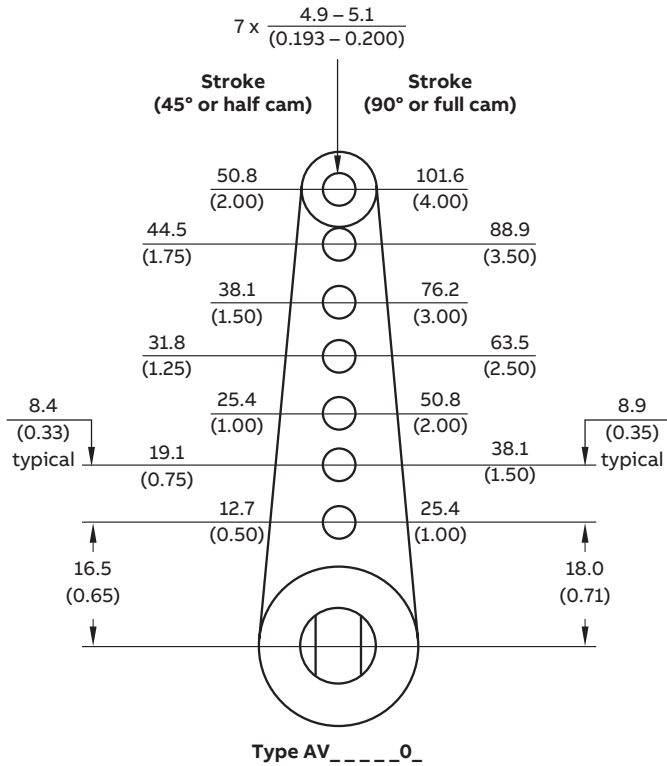

Figure 11 Drive arm dimensions

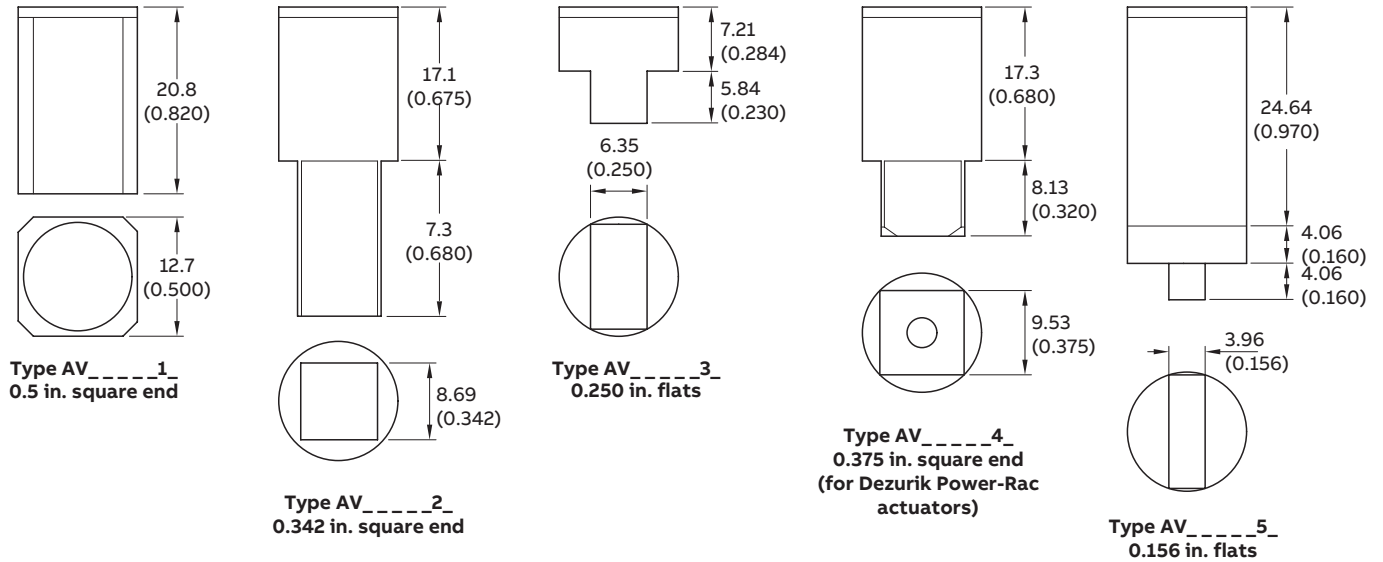

Figure 12 Drive shaft options dimensions

Electrical connections

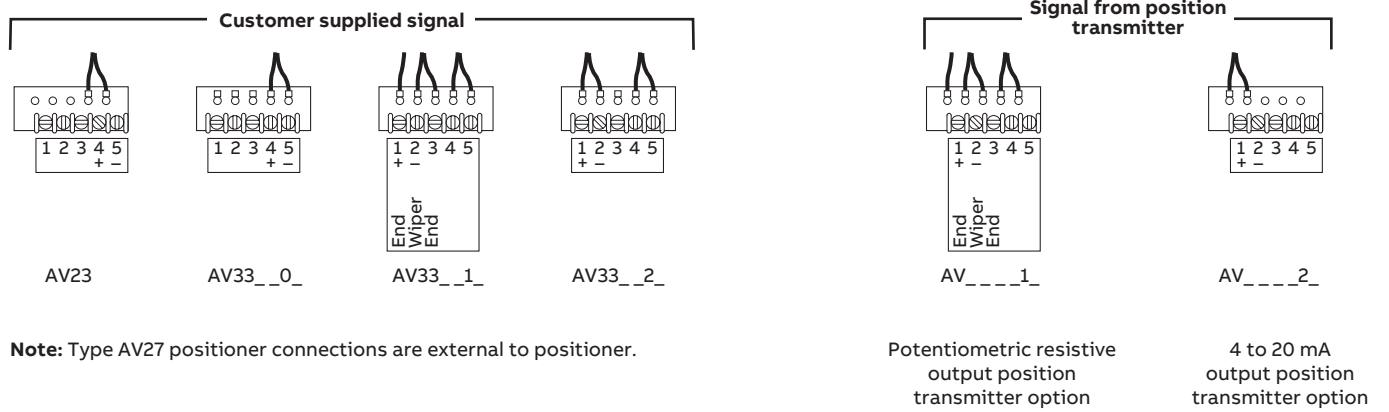

Figure 13 Signal input and output connections

Agency approvals

Nomenclature	Approval / Certification (see Notes below)
All (see Notes)	FM approvals (FM) cFMus approved as non-incendive for: Class I, Division 2, Groups A, B, C and D Class II, Division 2, Groups F and G Class III, Division 2
	Canadian Standards Association (CSA): See FM approvals cFMus
AV27__0__	FM approvals (FM) FM approved as: Explosion-proof for Class I, Div 1, Grps B, C and D Dust-ignition-proof for Class II and III, Div 1, Grps E, F and G Intrinsically safe for Class I, II and III, Div 1, Grps A through G
	Canadian Standards Association (CSA): Certified as: Explosion-proof for Class I, Div 1, Grps B, C and D Dust-ignition-proof for Class II and III, Div 1, Grps E, F and G Intrinsically safe for Class I, II and III, Div 1, Grps A through G
All	This product complies with all applicable European Community product requirements and specifically with those required to display the CE marking on the product nameplate.

Notes.

- cFMus = FM approved for both Canadian and US requirements.
- From 1st June 2014, AV1 and AV2 are approved only for non-incendive installations.
- Non-incendive hazardous locations approvals are for ambient conditions of -25 to 40 °C (-13 to 104 °F), 86 to 106 kPa (12.5 to 15.7 psig) with a maximum oxygen concentration of 21 %.

Accessories

Accessory	Description
Mounting kits	Kit number 5327321_ _ . Dependent on valve stem size. Refer to Table 1 for ABB retrofit kits.
Speed control orifices	Regulates time constant of positioner and final control device. Orifices are installed directly into positioner output ports – see Table 2. Speed adjustment can also be controlled by using the internal stroke adjustment screws.
Pressure gages	For reading signal, supply and output pressures – see Table 3.
Blank cam	Part number 5400277A1. Used to characterize the positioner if the standard cams (square, linear, square root) will not produce the desired relationship. Blank cam must be profiled. Note: This option is no longer available.
Supply air regulator	See Table 4.
Air filters	Installs in supply air line to prevent particles from entering the positioner that can lead to malfunctions – see Table 5.
Manifold filters	For addition or replacement of secondary air filters on manifold-equipped positioners. Kit number 258487A1.
Bypass valve assembly (Type AV1_ _ 1 only)	Part number 5326945A1. External by-pass valve for single-acting diaphragm applications only. Permits transfer of pneumatic control signal directly to diaphragm so that final control element can be operated while positioner is being serviced.

Kit number	Drive nomenclature	Retrofit mounting kit
5400309A1	UP1, UP2	AP positioner to
258493A1	UP3, UP4	AV positioner
258494C1	UP5, UP6	
258527C1	AC0404	ABB part number pilot valve
258528A1	AC0608	positioner to AV positioner
258529A1	AC0816	
258530A1	AC1016	
258527C1	AC0404	AP positioner to
258528A1	AC0608	AV positioner
258529A1	AC0816	
258530A2	AC1016	

Table 1 Rotary actuator retrofit mounting kits

Part no.	Size mm (in)
5327327A1	1.02 (0.04)
5327327A2	Blank (drill to suit)

Table 2 Speed control orifices

Part no.	Legend	Range	
		kPa	psig
5326605A4	Instrument	0 to 200	0 to 30
5326605A5	Supply*	0 to 1,000	0 to 160
5326605A6	Output	0 to 1,000	0 to 160

* Optional manifold provides gage ports, 1 for instrument (internal input signal) and 2 output gages. Supply gage can be installed in supply line (piping by customer).

Table 3 Pressure gages

Part no.	Outlet pressure (psig)	Maximum inlet pressure (psig)	Inlet / outlet connections
1951029D5	2 to 125	250	¼ NPT

Table 4 Supply air regulators with gages

Part no.	Maximum outlet pressure (psig)	Maximum inlet pressure (psig)	Inlet / outlet connections
5328563D2	250	250	¼ NPT

Table 5 Supply air filters

Mounting kits

Dimensions in mm (in)

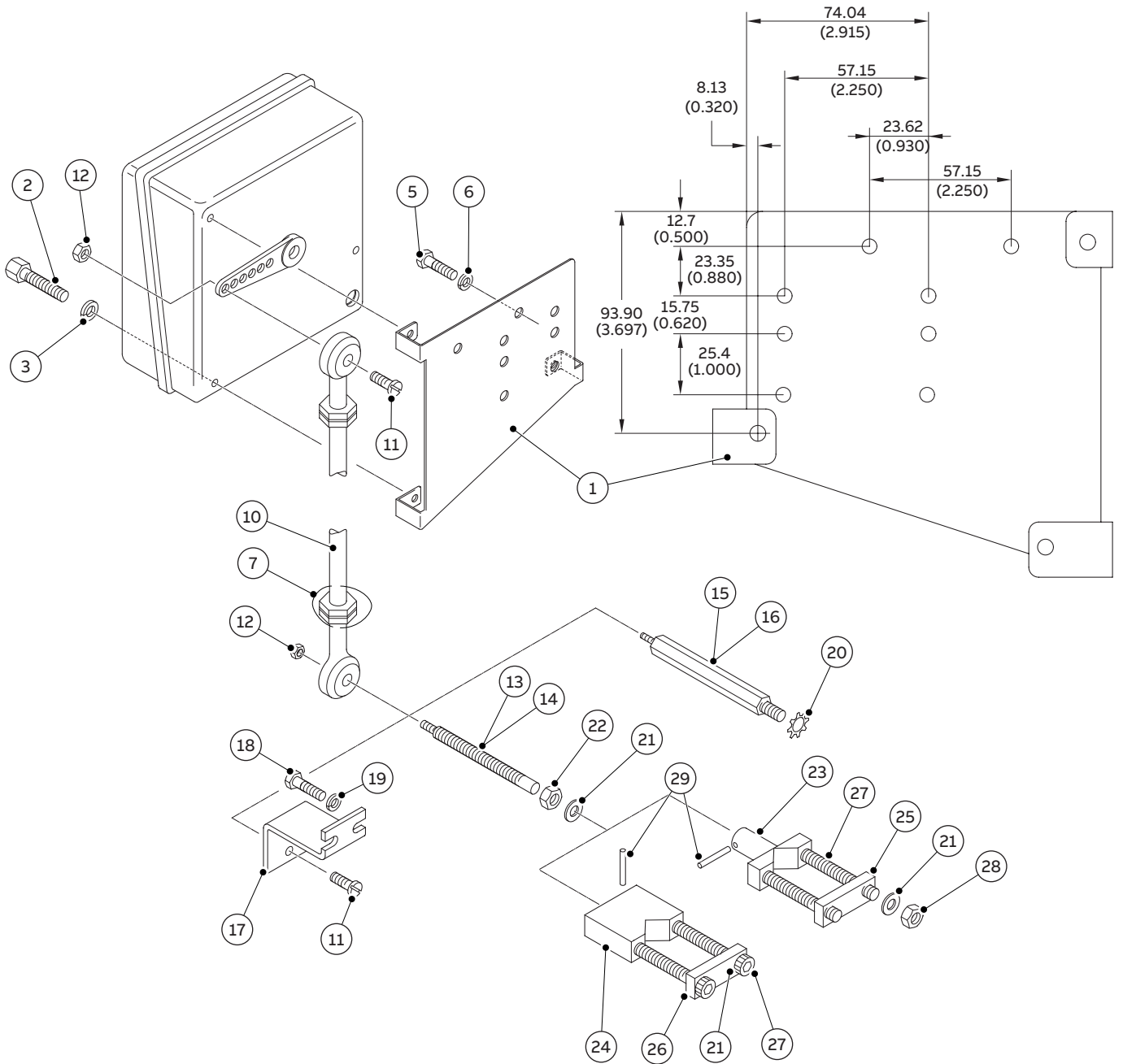

Tables 6, 7 and 8 identify the parts shown above for the available mounting kits.

Item	Part number	Description
①	5400266A1	Positioner mounting bracket
②	0.250-20 x 0.750	Screw, socket head (3)
③	0.25	Lock washer, regular spring (3)
⑤	0.312-18 x 0.625	Cap screw, hexagonal socket head (2)
⑥	0.312	Lock washer, regular spring (2)
⑦	R6440-0005	347 stainless steel wire, 0.300 dia., 6 in
⑧*	19934A248	Spacer
⑨*	0.190-32 x 1.125	Screw, pan head machine
⑩	5312449A4	Connecting link, 12 in (cut to fit)
⑪*	0.190-32 x 0.875	Screw, pan head machine (2)

Table 6 Mounting kit number 5327321A12 – valve stem diameter 0.375 to 0.750 in (Positioner mounting kits for direct or reverse acting diaphragm actuators and single or double-acting piston actuators with linear (reciprocating) motion)

Item	Part number	Description
⑫	197120A5	Nut, elastic stop (2)
⑬	5311690G1	Adjustable stud, 2.69 in
⑭	5311690G2	Adjustable stud, 3.43 in
⑰	0.375	Lock washer, med spring (3)
⑱	0.375-24	Nut, hexagonal jam
⑳	5311687A2	Stem clamp, 0.375 to 0.750 in dia.
㉑	5311691C1	Clamp plate, 0.375 to 0.750 in dia.
㉒	0.375-16 x 1.50	Screw, hexagonal socket head cap (2)
㉓	0.375-16	Nut, hexagonal jam (2)
㉔	0.125 dia x 0.750	Groove pin, type 1

Item	Part number	Description
①	5400266A1	Positioner mounting bracket
②	0.250-20 x 0.750	Screw, socket head (3)
③	0.25	Lock washer, regular spring (3)
⑤	0.312-18 x 0.625	Cap screw, hexagonal socket head (2)
⑥	0.312	Lock washer, regular spring (2)
⑦	R6440-0005	347 stainless steel wire, 0.300 dia., 6 in
⑧*	19934A248	Spacer
⑨*	0.190-32 x 1.125	Screw, pan head machine
⑩	5312449A4	Connecting link, 12 in (cut to fit)

Table 7 Mounting kit number 5327321A13 – valve stem diameter 0.750 to 1.000 in (Positioner mounting kits for direct or reverse acting diaphragm actuators and single or double-acting piston actuators with linear (reciprocating) motion)

Item	Part number	Description
⑪*	0.190-32 x 0.875	Screw, pan head machine (2)
⑫	197120A5	Nut, elastic stop (2)
⑭	5311690G2	Adjustable stud, 3.43 in
⑰	0.375	Lock washer, medium spring (3)
⑱	0.375-24	Nut, hexagonal jam
㉒	5312483E1	Stem clamp, 0.750 to 1.00 in dia.
㉓	5312471D1	Clamp plate, 0.750 to 1.00 in dia.
㉔	0.375-16 x 1.50	Screw, hexagonal socket head cap (2)
㉕	0.125 dia x 0.750	Groove pin, type 1

Item	Part number	Description
①	5400266A1	Positioner mounting bracket
②	0.250-20 x 0.750	Screw, socket head (3)
③	0.25	Lock washer, reg spring (3)
⑤	0.312-18 x 0.625	Cap screw, hexagonal socket head (2)
⑥	0.312	Lock washer, reg spring (2)
⑦	R6440-0005	347 stainless steel wire, 0.300 dia., 6 in
⑧*	19934A248	Spacer
⑨*	0.190-32 x 1.125	Screw, pan head machine
⑩	5312449A4	Connecting link, 12 in (cut to fit)
⑪*	0.190-32 x 0.875	Screw, pan head machine (2)
⑫	197120A5	Nut, elastic stop (2)
⑮	5319500A11	Drive stud, 2.69 in

Table 8 Mounting kit number 5327321A14 (for use on Fisher actuators) – valve stem diameter 0.375 to 0.750 in (Positioner mounting kits for direct or reverse acting diaphragm actuators and single or double-acting piston actuators with linear (reciprocating) motion)

Item	Part number	Description
⑯	5319500A1	Drive stud, 3.43 in
⑰	5323155A1	Stud bracket
⑱	0.312-18 x 0.500	Screw, hexagonal head (2)
⑲	1218-00	Lock washer, shake-proof (2)
㉑	5319524A1	Lock washer, star (3)
㉒	0.375	Lock washer, medium spring (3)
㉓	0.375-24	Nut, hexagonal jam
㉔	5311687A2	Stem clamp, 0.375 to 0.750 in dia.
㉕	5311691C1	Clamp plate, 0.375 to 0.750 in dia.
㉖	0.375-16 x 1.50	Cap screw, hexagonal socket head (2)
㉗	0.375-16	Nut, hexagonal jam (2)
㉘	0.125 dia x 0.750	Groove pin, type 1

* When fastening item ⑩ to drive arm at first hole (nearest drive shaft), use items ⑧ and ⑨ and omit 1 of Item ⑪.

Ordering information

Pneumatic positioner type AV1

The AV1 pneumatic positioner accepts linear or non-linear pneumatic input signal ranges to provide sensitive, accurate positioning of a pneumatic final control element.

A feedback cam in the positioner establishes the actual position of the final control element and can be characterized to provide a square root, square or linear relationship to the input signal.

Split range signal – can be field calibrated for 100 % stroke for 50 % signal span or 50 % stroke for 100 % signal span.

The optional manifold / gage block provides gage ports – one for instrument (internal input signal) and two for positioner output. A supply gage can be installed in the supply line (piping by customer).

When converting a 3 to 15 psig positioner to a 3 to 27 input positioner, or vice versa, both the diaphragm assembly kit and the appropriate diaphragm cover are required.

Refer to Note 4 for AV1 application details.

Pneumatic positioner	AV1	X	X	X	X	X	X
Input signal							
0.2 to 1 bar (3 to 15 psi), standard temperature range –40 to 82 °C (–40 to 180 °F)	1						
0.2 to 1.86 bar (3 to 27 psi), standard temperature range –40 to 82 °C (–40 to 180 °F)	2						
0.2 to 1 bar (3 to 15 psi), extended temperature range –20 to 121 °C (–4 to 250 °F)	5						
0.2 to 1.86 bar (3 to 27 psi), extended temperature range –20 to 121 °C (–4 to 250 °F)	6						
Stroke or rotary motion							
12.7 to 50.8 mm (0.5 to 2.0 in) or 45° rotation		1					
25.4 to 101.6 mm (1.0 to 4.0 in) or 90° rotation		2					
Manifold / gage block							
No manifold				0			
Manifold with equalizing valve, filters and gage ports (see Notes 1 and 2)				1			
Gage block, gage ports only				3			
Position transmitter							
No position transmitter					0		
Potentiometric resistive transmitter (see Note 2)					1		
4 to 20 mA output (see Note 2)					2		
Drive shaft							
Standard with drive arm (for linear actuators) and UP3 / 4 / 5 / 6						0	
12.7 mm (0.500 in) square end (most common for 90° actuators)						1	
8.69 mm (0.342 in) square end (older DeZurik / K&M actuators)						2	
6.35 mm (0.250 in) flats (UP1 / UP2 manufactured after August, 1995)						3	
9.525 mm (0.375 in) square end (for DeZurik PowerRac actuators)						4	
4 mm (0.157 in) flats (for NAMUR rotary mounting)						5	
Options							
No options							0
NEMA 4X enclosure rating (must be installed in accordance with drawing 258567)							N
Performance series, high pneumatic gain							P

Notes.

1. Required for double acting actuators with manual override (for example, UP or AC actuators)
2. Not available with input signal codes 5 and 6
3. This optional manifold is recommended on all AC and UP Drives. Not available for AV15_____ and AV16_____
4. From 1st June 2014, AV1 is approved only for general purpose and non-incendive installations.

Electropneumatic positioner type AV2

The AV2 electropneumatic positioner receives a 4 to 20 mA input from a controller and converts the signal via an I/P converter to a pneumatic output that positions a power actuator.

The AV2 can be adjusted by the user to default automatically to either the fully open or fully closed position in the event of input signal loss.

The optional manifold / gage block provides gage ports – one for instrument (internal input signal) and two for positioner output.

A supply gage can be installed in the supply line (piping by customer).

Electropneumatic positioner	AV2	X	X	X	X	X	X
Intrinsically safe / explosion-proof design							
Non-incendive design cFMus (see Note 1)	3						
Explosion-proof and intrinsically safe design FM/CSA (see Note 2)	7						
Stroke or rotary motion							
4 to 20 mA input, 12.7 to 50.8 mm (0.5 to 2.0 in) or 45° rotation		1					
4 to 20 mA input, 25.4 to 101.6 mm (1.0 to 4.0 in) or 90° rotation		2					
Manifold / gage block							
No manifold				0			
Manifold with equalizing valve, filters and gage ports (see Notes 3 and 4)				1			
Gage block, gage ports only (see Note 4)				3			
Position transmitter							
No position transmitter					0		
Potentiometric resistive transmitter (see Note 3)					1		
4 to 20 mA output (see Note 3)					2		
Drive shaft							
Standard with drive arm (for linear actuators) and UP3 / 4 / 5 / 6						0	
12.7 mm (0.500 in) square end (most common for 90° actuators)						1	
8.69 mm (0.342 in) square end (older DeZurik / K&M actuators)						2	
6.35 mm (0.250 in) flats (UP1 / UP2 manufactured after August, 1995)						3	
9.525 mm (0.375 in) square end (for DeZurik PowerRac actuators)						4	
4 mm (0.157 in) flats (for NAMUR rotary mounting)						5	
Options							
No options							0
NEMA 4X enclosure rating (must be installed in accordance with drawing 258567) (see Note 4)							N
Performance series, high pneumatic gain							P

Notes.

1. From 1st June 2014, AV23 _____ is approved only for general purpose and non-incendive applications
2. AV27 _____ is FM/CSA approved (explosion-proof or intrinsically safe) for Class I, Division 1 applications.
3. Required for double acting actuators with manual override (for example, UP or AC actuators)
4. Not available with intrinsically safe / explosion-proof design code 7.

Accessories

Accessories for AV1 and AV2 (except where indicated)

Description	Part number
Mounting kits, for diaphragm actuators with yoke mounting bosses (includes mounting bracket, linkage and hardware)	
For stem size 9.53 to 19.1 mm (0.375 to 0.75 in), adjustable stud length 68.2 mm (2.687 in)	5327321A12
For stem size 19.2 to 25.4 mm (0.75 to 1.0 in), adjustable stud length 87.3 mm (3.437 in)	5327321A13
For stem size 9.53 to 25.4 mm (0.375 to 1.0 in), adjustable stud length 86.5 mm (3.406 in) – Fisher	5327321A14
Mounting bracket, for reciprocating valves (contained in above kits)	5400266A1
Connecting link, adjustable length 304.8 mm (12 in) (contained in above kits)	5312449A4
Mounting kits, for retrofitting UP drives from AP to AV positioners	
For UP10, UP20	5400309A1
For UP30, UP40	258493A1
For UP50, UP60	258494C1
Mounting kits, for retrofitting AC drives from old Bailey-Fischer and Porter part number positioners to AV positioners	
For AC0404	258527C1
For AC0608	258528A1
For AC0816	258529A1
For AC1016	258530A1
Mounting kits, for retrofitting AC drives from AP to AV positioners	
For AC0404	258527C1
For AC0608	258528A1
For AC0816	258529A1
For AC1016	258530A2
Mounting kits, for adding a Beacon™ indicator or a limit switch package onto the cover of an AV positioner	
For adding a Beacon™ Indicator (includes a Westlock black and yellow indicator)	258570B1
For adding limit switches, Westlock 2004/2007 or equivalent (does not include limit switch package) – for more information see drawing 258570B	258570A4
Speed control orifices, for use when more than one final control element is being operated from the same control signal and designed to equalize speeds between units	
1.016 mm (0.040 in)	5327327A1
Blank (drill as required)	5327327A2
Pressure gages, for calibration	
Instrument – 0 to 30 psig range (AV1 only)	5326605A4
Supply – 0 to 160 psig range	5326605A5
Output – 0 to 160 psig (quantity 2 required for double-acting applications)	5326605A6
External by-pass valve (for single acting diaphragm applications only)	
Permits transfer of pneumatic control signal directly to diaphragm to enable final control element to be operated during positioner servicing. Use with AV1 __ 1 __ only	5326945A1
Supply air filter (coalescing) with bracket. Maximum inlet pressure 250 psi, ¼ – 18 NPT	5328563D2
Supply air regulator with bracket. Maximum inlet pressure 250 psi, ¼ – 18 NPT	1951029D5

Spare parts

Parts kits for AV1 and AV2

Description	Part number
Diaphragm parts	
Diaphragm assembly kit (3 to 15 psig and 3 to 27 psig)	258486A1
3 to 15 psig positioner, diaphragm cover	5400295A1
3 to 27 psig positioner, diaphragm cover (AV1 only)	5400295A2
Note. When converting a 3 to 15 psig positioner to a 3 to 27 psig positioner, or vice versa, both the diaphragm assembly kit and the appropriate diaphragm cover are required.	
Gage block kit for field addition	258569A1
Manifold parts	
Manifold kit with equalizing valve for field addition	258491A1
Filter replacement kit	258487A1
Shut off valve kit	258270A1
Note. The optional manifold/gage block provides gage ports – one for instrument (internal input signal) and two output gages. A supply gage can be installed in the supply line (by customer)	
Characterizing cams	
Forward-acting full rise cam, 90 degree rotation	5400281A1
Reverse-acting full rise cam, 90 degree rotation	5400281A2
Forward-acting half rise cam, 45 degree rotation	5400289A1
Reverse-acting half rise cam, 45 degree rotation	5400289A2
Pilot valve assemblies	
Pilot valve assembly kit	258488B1
Pilot valve assembly kit (performance series, AV _____ P)	258488A3
Pilot valve assembly kit (high temperature model, AV15/6)	258488A2
Pilot valve assembly kit (high temperature and performance series model, AV1 5/6 _____ P)	258488A4
Feedback arm	
Feedback arm for linkage attachment, for 90 degree cam rotation	5327445A1
Feedback arm for linkage attachment, for 45 degree cam rotation	5327445A2
Cover assembly (includes cover, window, gasket and plastic cover inserts)	258545A1
Cam follower arm assembly	258544A1
Position transmitter – field addition kits	
Pneumatic position transmitter	258492A1
4 to 20 mA position transmitter	258670A1
Cam shaft	
½ in square end connection	5400278A1
Tapered end connection for linear feedback arm	5400287A1
0.342 in square end for older DeZurik / K&M actuators	5400287A2
0.250 in flats (UP1 / UP2 after 8/95)	5400287A3
0.375 in Square End (for DeZurik PowerRac actuators)	5400287A4
4 mm (0.156 in) flats (for Namur rotary mounting)	5400287A5
Also requires conversion plate	5400321A1

Parts kits for AV2

Description	Part number
I/P converter replacement kit (AV23 only)	258651A1
Explosion-proof positioner parts (AV27 only)	
Kit to mount explosion-proof I/P converter to pneumatic positioner (does not include I/P)	258612A1
I/P converter for AV27	1949547A2